

CONDOR

Mechanical Key Cutting Machine

XC-002

User Manual

xhorse® Shop.us



TABLE OF CONTENTS

1)SAFETY PRECAUTIONS AND WARNINGS-----	01
2) GENERAL INFORMATION-----	02
2.1BRIEF INTRODUCTION-----	02
2.2CHARACTERISTICS-----	02
3) PRODUCT PACKAGING CHECKLIST-----	03
4) OVERVIEW	
4.1 SCHEMATIC-----	06
4.2 SPECIFICATIONS AND PARAMETERS-----	07
4.3 MAIN COMPONENTS AND FUNCTION INSTRUCTION-----	08
5) MACHINE INSTALLATION AND PREPARATION	
5.1 INSTALLING THE MAIN HANDLE-----	15
5.2 INSTALLING THE SUB HANDLE-----	16
5.3 INSTALLING AND REMOVING PROBE/CUTTER-----	17
5.4 CLAMP INSTALLATION-----	18
5.5 PROBE/CUTTER HEIGHT LEVEL ADJUSTMENT-----	19
5.6 ROTATION ADJUSTMENT-----	20
6) OPERATING INSTRUCTIONS	
6.1 KEY ALIGNMENT-----	21
6.2 SELECTION RULES OF CLAMP SIDES-----	22
7) MAINTENANCE-----	23
8) WARRANTY AND AFTER SALESSERVICE-----	24
9) APPENDIX-----	25

1 . SAFETY PRECAUTIONS AND WARNINGS

To prevent personal injury or machine damage, users should carefully observe the instructions in this operation manual and adopt following safety precautions:

- Always operate the machine under a safe condition.
- Place the machine on a horizontal surface, which should be firm enough to carry.
- Do not expose the machine to the direct sunlight, or place the machine in any wet, oily, or dusty area.
- Please keep the machine clean and dry, and maintain at least 30cm distance to the wall for ventilation.
- Please wear the safety glasses that meets ANSI standard.
- Keep clothing, hair, hands, tools, test equipment, etc. away from all moving parts.
- Do not leave the machine while it is operating, and someone specifically for monitoring is also required.
- Do not place any object on the machine during running.
- Must connect to the grounded power outlet, please do not use the power outlet if it is broken, loosen or with substandard power.
- Please unplug the machine during maintenance or it is idle.
- Immediately shut down the machine if any exception occurs. The power switch locates near the power cord connector, at the lower rear part of the machine.
- Please place the machine out of the reach of children.

2 . GENERAL INFORMATION

2.1 BRIEF INTRODUCTION

Thank you for choosing CONDOR XC-002 Mechanical Key Cutting Machine. XC-002 Mechanical Key Cutting Machine is a professional device. It enables locksmiths to copy and process keys more efficiently and accurately for vehicles or civil use. The careful reading of this manual before use is a quite crucial precondition for safety. For occasional reference, please keep this user manual properly.

2.2 CHARACTERISTICS

CONDOR XC-002 Mechanical Key Cutting Machine contains following characteristics:

- **Ergonomic design provides better user experience**
- **Aluminum-casting body make it more reliable and durable**
- **Adjustable high-speed motor ensures the stability and fluency of operation.**
- **Built-in indicator lights make the height level adjustment easier**
- **Cross rail guarantees the accuracy**
- **Supporting track and dimple cutting, that can process special keys**
- **More key types are available because of 4-side rotary clamp**

3. PRODUCT PACKAGING CHECKLIST

The whole package covers all following items, if missing, please contact your dealer.

Name	Schema	Quantity	Description
Main body		1	Key machine body
Upper rubber mat		1	Temporarily carry light items
Multi-functional clamp		1	Key carrier, can rotates in four sides
Key alignment block blade		1	Use in key alignment
2.5mm cutter ($\text{Ø}2.5 \times \text{Ø}6 \times 40\text{L}$)		1	Available for most mechanical keys
1.5mm cutter ($\text{Ø}1.5 \times \text{Ø}6 \times 40\text{L}$)		1	Available for elaborate cutting
Tracer ($\text{Ø} 1.5 \times \text{Ø} 2.5 \times \text{Ø} 6 \times 45\text{L}$)		1	The tool for detection

Main handle		1	Control the height of tracer and cutter
Sub-handle		1	Control the position of working bench
Power cord(1.5m)		1	Connect to power outlet (Chinese Standard)
Power cord(1.5m) (optional)		0	Connect to power outlet (British Standard)
Power cord(1.5m) (optional)		0	Connect to power outlet (European Standard)
Power cord(1.5m) (optional)		0	Connect to power outlet (American Standard)
Brush		1	For clean
2.5mm Allen wrench		1	Tool for the installation of tracer and cutter
4mm Allen wrench		1	Tool to tighten the clamp
Product packaging checklist		1	Product Delivery Inspection Certificate Product Packaging check
User manual		1	Machine installation and operating instruction

Note :

- ★ For the product improvement, color, design and structure may be different, please in kind prevail.
- ★ The cutter should be replaced timely to maintain the cutting effectiveness.
- ★ Please use 3A fuse.

4. OVERVIEW

4.1 SCHEMATIC

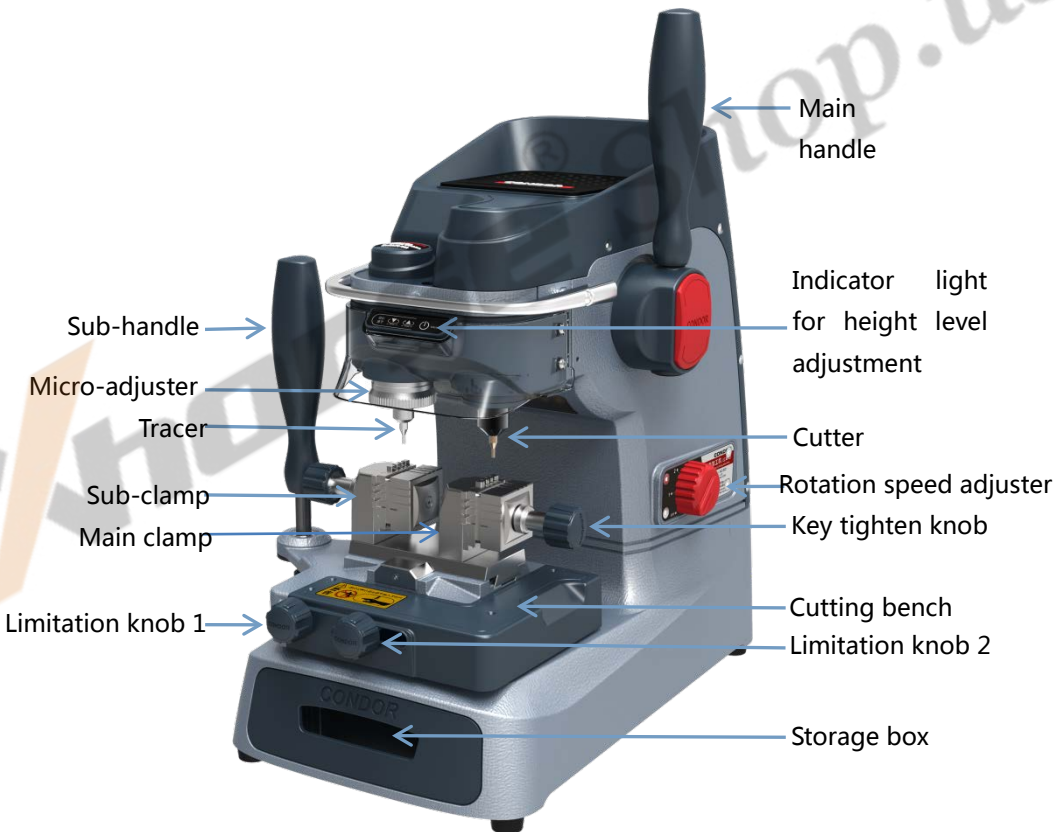

4.2 SPECIFICATIONS AND PARAMETERS

Input Voltage	220VAC
Input Frequency	50Hz
Power Consumption	200W
Motor Rotation Speed	MAX 10000rpm 1 st gear , 6000rpm 2 nd gear , 8000rpm
Motor Torque	1 st gear , torque 0.4N 2 nd gear , torque 0.3N
Working Temperature	0~50°C
Humidity	10~90%
Travel of Spindle	27mm
Travel of Cutting Bench	Horizontal : 38mm Vertical : 50mm
Decibel	77dB
Net Weight	23KG
Gross Weight	28KG
Machine Dimension	L 298mm×W 445mm×H 525mm
Package Dimension	L 595mm×W 550mm×H 375mm



MACHINE DIMENSION



PACKAGE DIMENSION

4.3 MAIN COMPONENTS AND FUNCTION INSTRUCTION

4.3.1 SUB-HANDLE

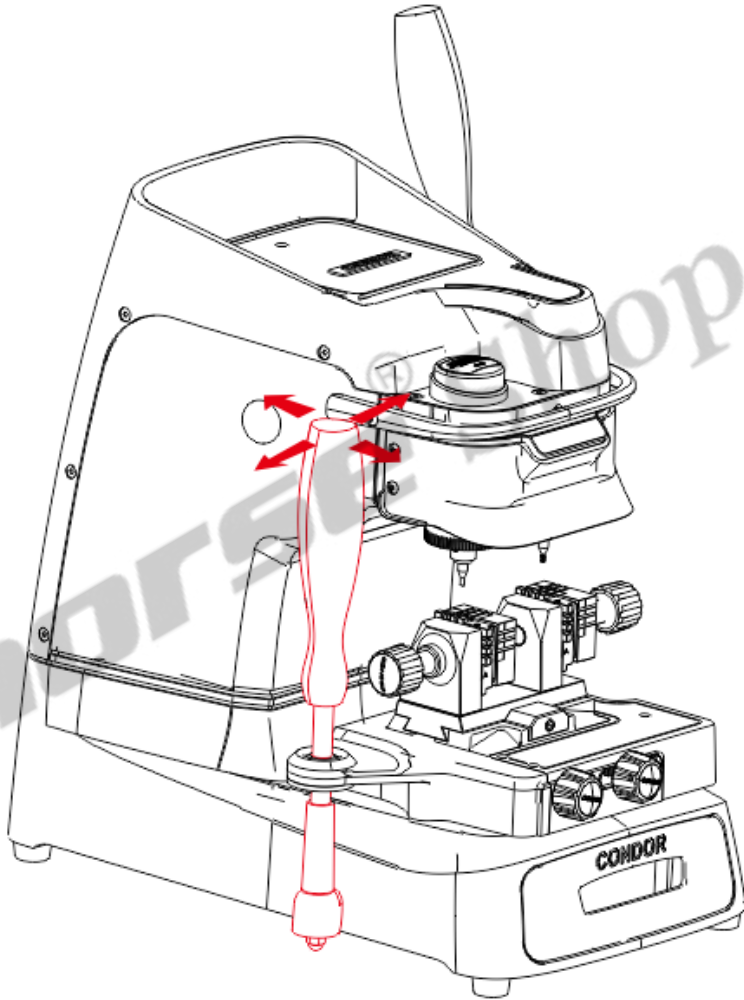

Ensure cutting bench' s horizontal movement is in a specified area.

4.3.2 MAIN HANDLE

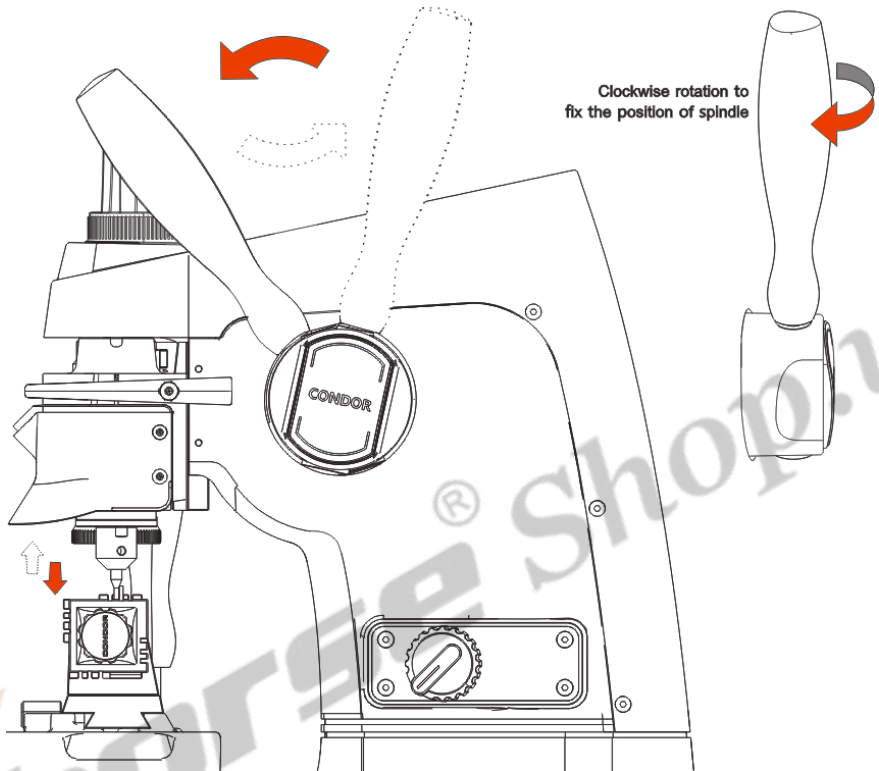

- 1) Pull or push the handle up and down to adjust the height of tracer and cutter. When releasing the handle, tracer will back to the original position.
- 2) Tighten the handle in the clockwise direction can fix the position of tracer and cutter.
- 3) The operation strength should be proper to avoid damage.

4.3.3 ROTATION SPEED ADJUSTER

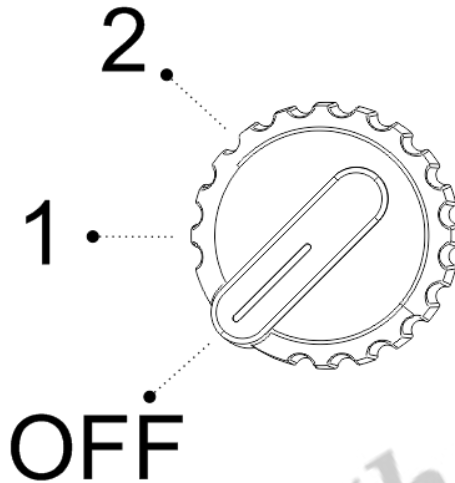

There are four gears to control rotation speed - neutral, OFF, 1 and 2, respectively, means motor turnoff, standby, low speed and high speed four running modes.

4.3.4 INDICATOR LIGHT OF HEIGHT LEVEL ADJUSTMENT

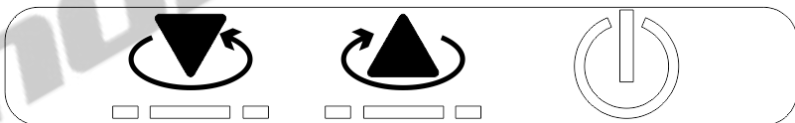

- 1) If the heights of tracer and cutter are the same, two indicator lights will be both on when tracer and cutter' s tops have contacted with the clamp by main handle.
- 2) If trace is higher than cutter, the left indicator light will be on, means "Lower" .
- 3) If trace is lower than cutter, the right indicator light will be on, means "Raise" .

4.3.5 MICRO-ADJUSTER

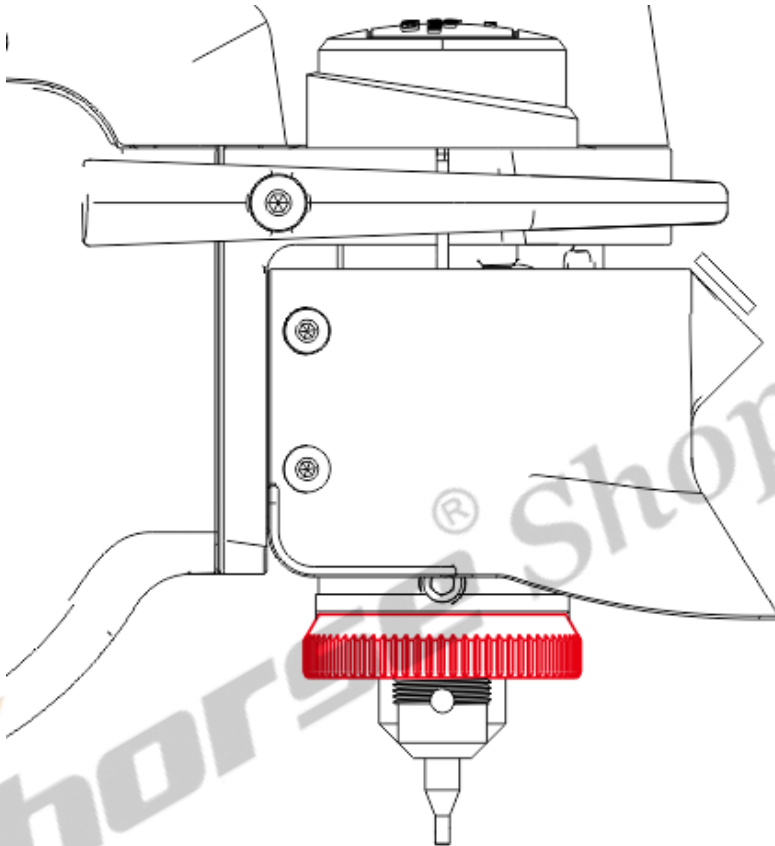

It is used to adjust the height of tracer, until its top is at the same height level as cutter' s.

(Clockwise rotating will raise the tracer and counterclockwise will lower it)

4.3.6 CUTTING BENCH

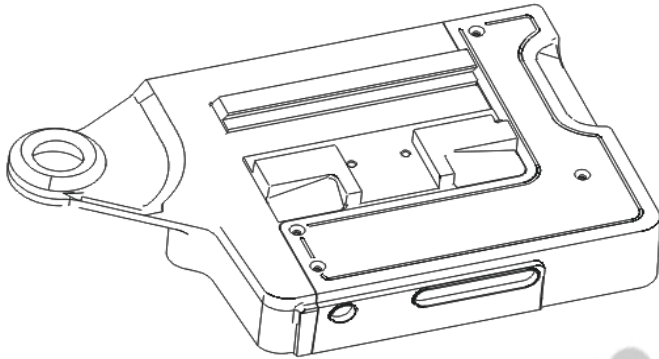

The sliding base is for the horizontal movement of clamp.
(The maximum slide distance is 38mm laterally and 50mm longitudinally.)

4.3.7 CLAMP

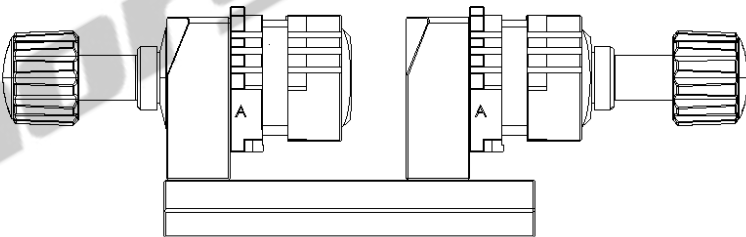

This is the key carrier (the left one is sub-clamp for original key and the right one is main clamp for key blank). Four sides A, B, C and D are rotary, and each of them has the place for key alignment. Please select the corresponding side in terms of key type and bitting.

NOTE: When cutting, the side of both two clamps must be the same.

4.3.8 KEY TIGHTNESS KNOB

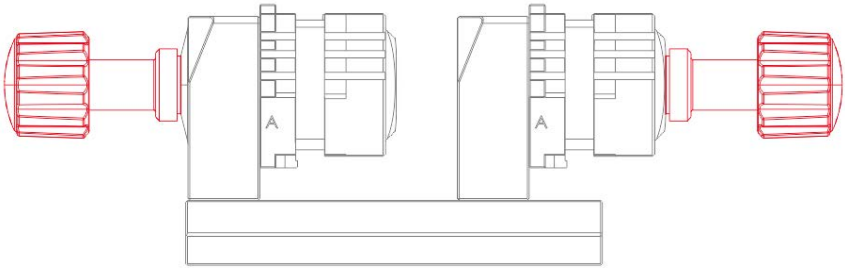

Put the original key and key blank into clamp spot and tighten, that to ensure the position shifting will not happen during the process. Please first loosen knobs, and then both clamps should be turn to the same side,

4.3.9 LIMITATION KNOB

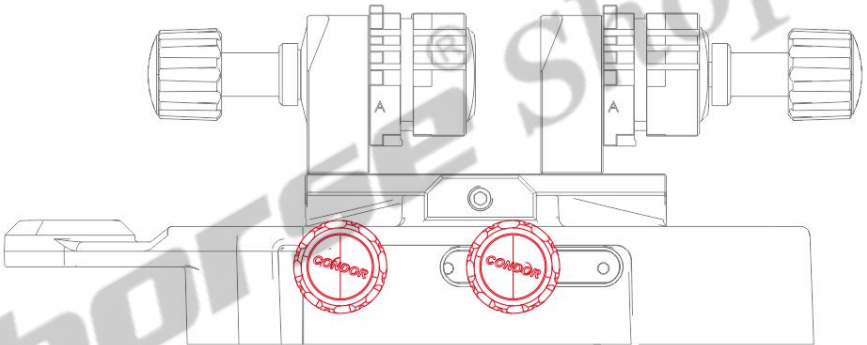

1) Knob 1 on the left is used to adjust cutting bench' s left and right moving. When this knob is tightened, bench can only move backwards and forwards.

Knob 2 on the right is used to adjust cutting bench' s sliding range. When this knob is tightened, the distance of bench' s left-to-right sliding is limited.

4.3.10 STORAGE BOX

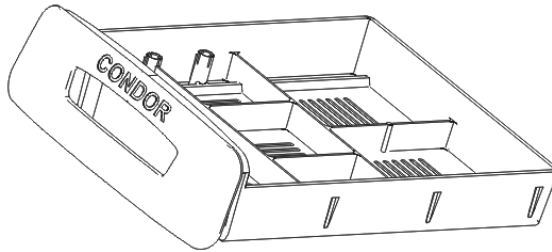

To place tracer, cutter, key blank, brunch and other materials and tools.

4.3.11 POWER CONTROL MODULE

The power connector, fuse and power switch are all located at the lower back of the machine.

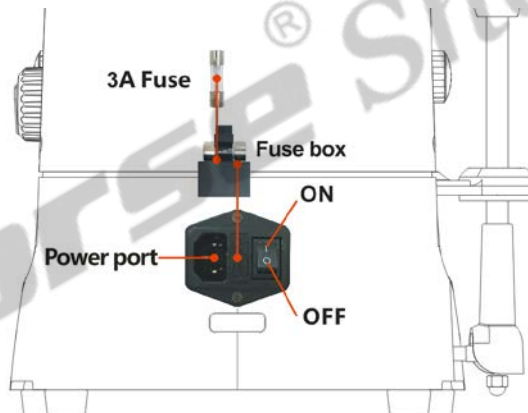

- 1) Insert the power cord into left port, then link to the grounded power outlet.
- 2) When switch the power to "ON" , machine enters into "Standby" mode.
- 3) To replace the fuse, please remove the box first, then change a new one and put the box back.

- ★ Please use 3A fuse.
- ★ When the machine is idle or maintaining, please turn off the power and unplug the power outlet.

xhorse® Shop.us

5. MACHINE INSTALLATION AND PREPARATION

5.1 INSTALLING MAIN HANDLE

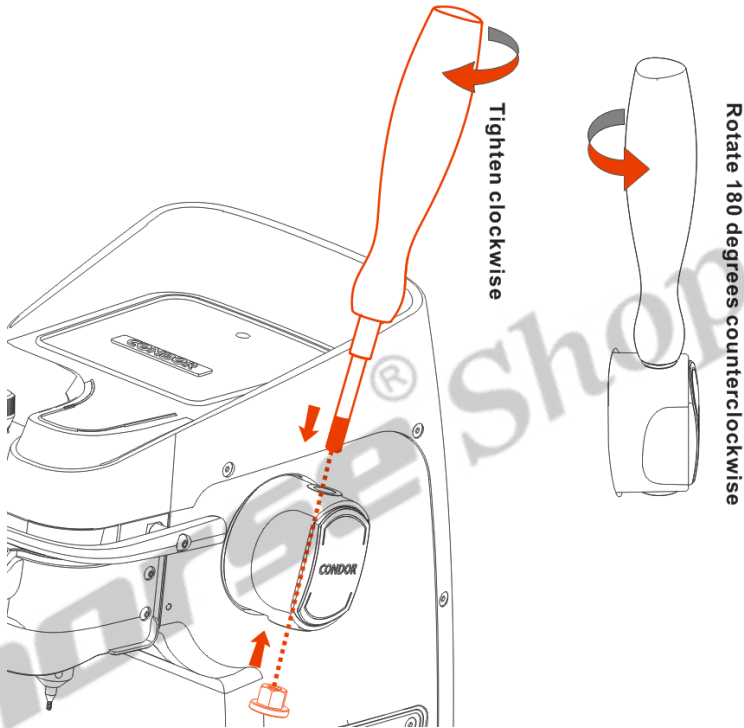

- 1) Insert the bottom of main handle into installing hole, which is by the right side of the machine body. Then cover the screw cap and rotate the handle clockwise until tightened.
- 2) If fully tightened, the main handle should be fix at a certain position and unable to move up or down.
- 3) If rotate the handle 180 degrees counterclockwise, the height of tracer and cutter can be changed freely.

5.2 INSTALLING SUB-HANDLE

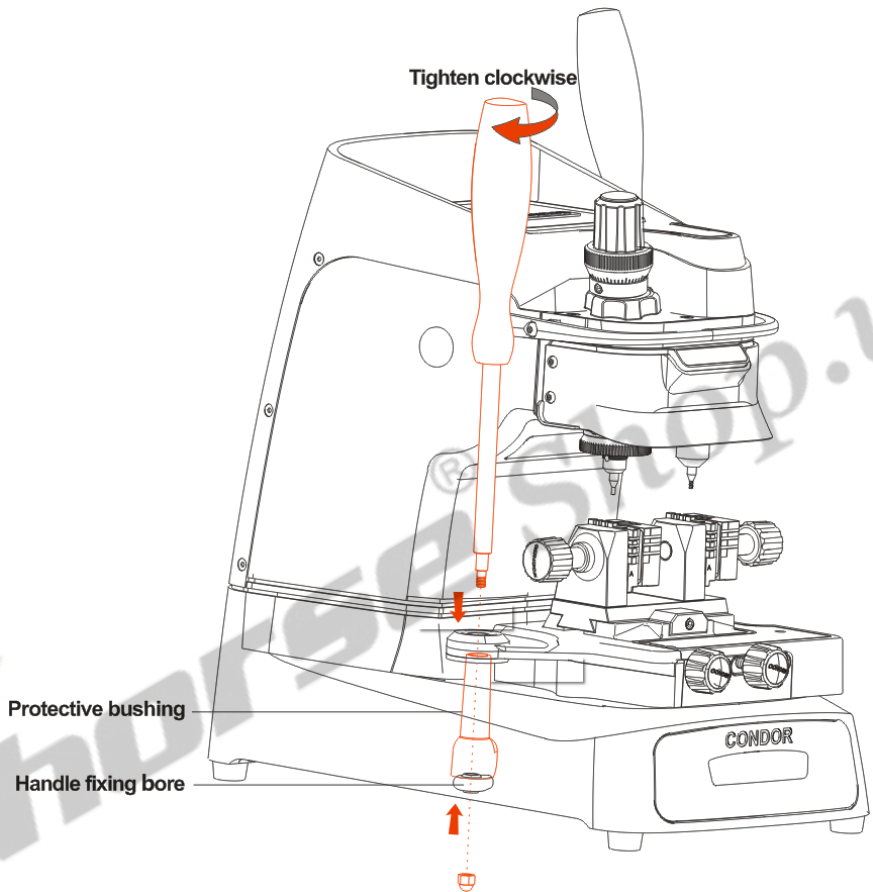

- 4) Insert the bottom of sub-handle into the installing hole, which is by the left side of the machine body. Put on the protective bushing and then plug in the lower bearing bore to avoid moving. Cover the screw cap and rotate the handle clockwise until tightened.

5.3 INSTALLING AND REMOVING PROBE/CUTTER

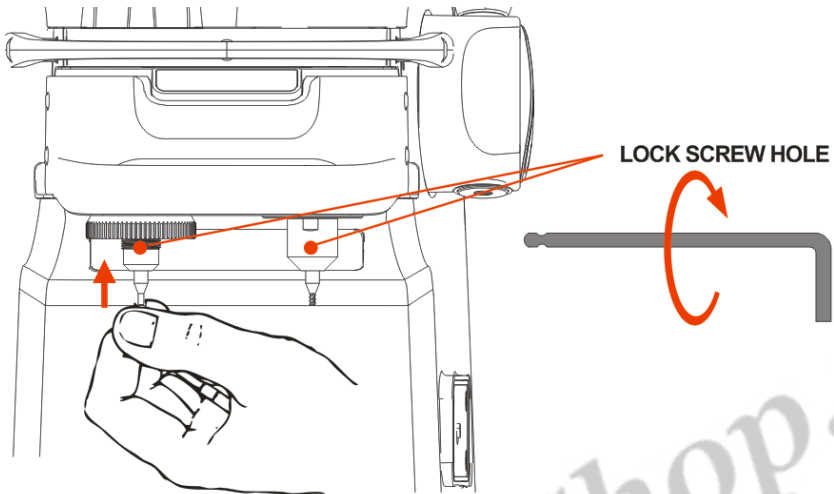

- 1) The left one is tracer and the right one is cutter. Put the tracer and cutter into the hole and to the top limit position. Then use 2.5mm Allen wrench to turn the lock screw clockwise respectively till the tracer and cutter are both tightened.

NOTE: When using 1.5mm cutter and 2.5mm cutter, tracer and cutter must select the top with the same diameter for processing.

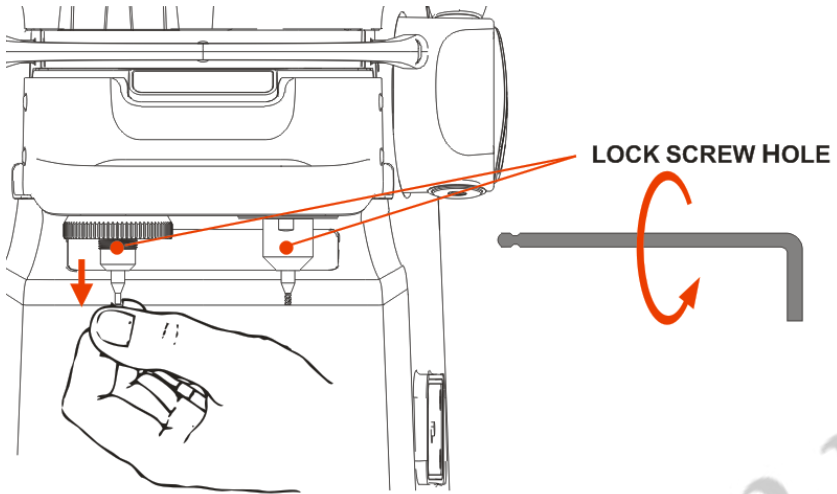

- 2) Insert the wrench into the hole, turn the lock screw counterclockwise, and then remove trace and cutter.

5.4 CLAMP INSTALLATION

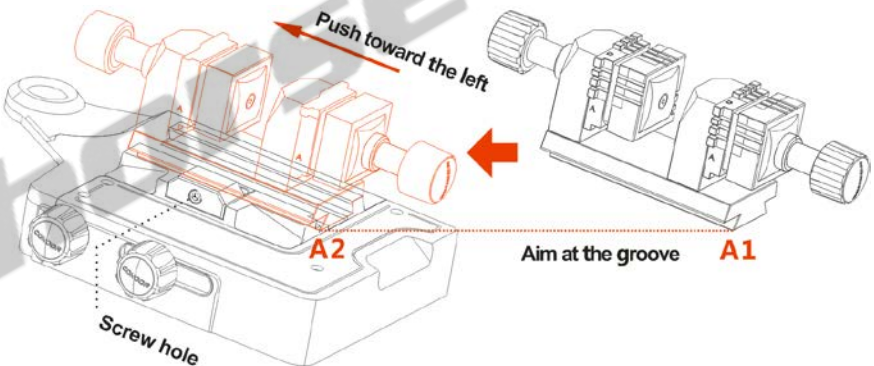

Aim the bump (A1: underneath the clamp) at the cutting bench' s groove (A2), push toward the left until A1 and A2 (shown above) are fully overlapped. Then use 4mm Allen wrench to tighten the screw.

5.5 PROBE/CUTTER HEIGHT LEVEL ADJUSTMENT

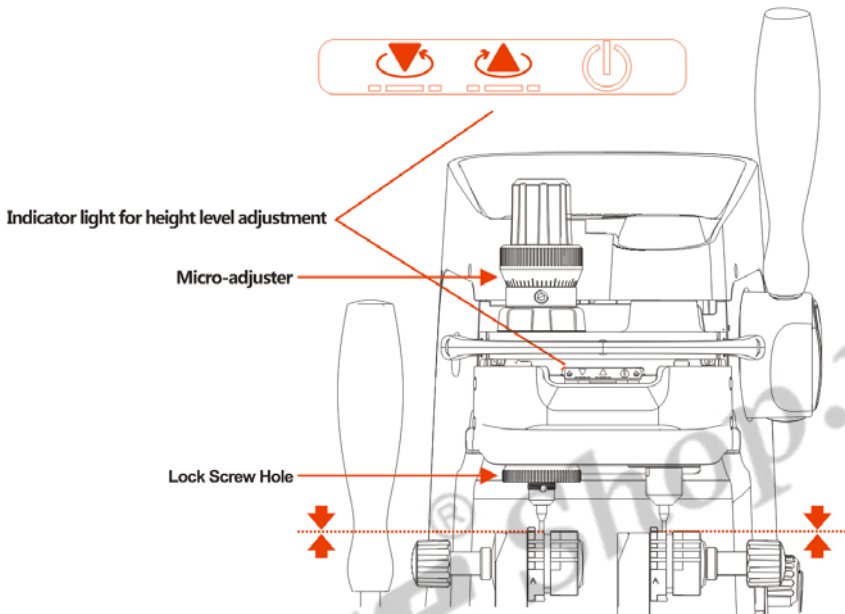

- 1) When the installation finished, push the main handle.
If the tracer is higher than cutter, the indicator light on the left will turn on.
- 2) If the tracer is lower than cutter, the indicator light on the right will turn on.

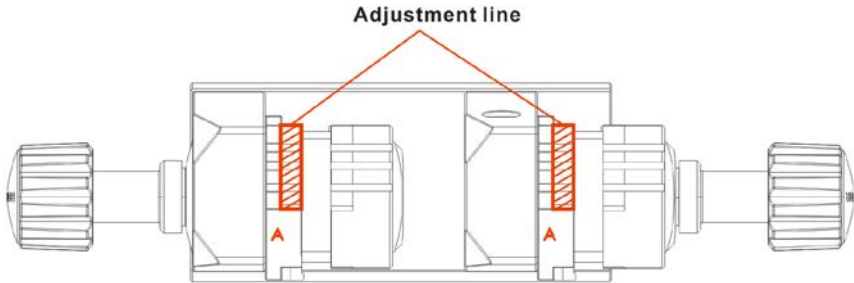

- 3) According to the signal of indicator light, rotate the Micro-adjuster until tracer and cutter' s tops have both touched the clamp. In other words, they are at the same height. Then two indicator lights will on, adjustment finished.

NOTE : During the height level adjustment, main clamp and sub-clamp must at the same side.

5.6 ROTATION SPEED ADJUSTMENT

Rotation adjustment knob locates at the right side of the machine. There are two gears to control the rotating speed of motor.

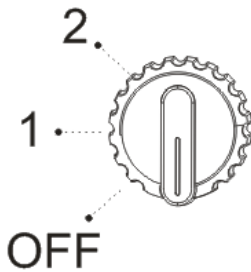

1) When the adjuster is at the neutral gear, motor stays at "Turnoff" mode; when it points to "OFF", the light will be on, means the machine is ready to work

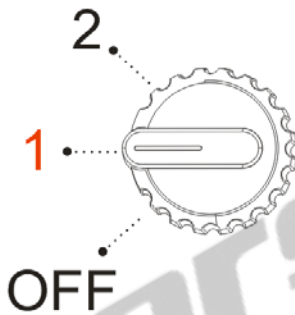

2) When the adjuster points to "1", the motor rotates at a low speed, about 6000rpm; when it points to "2", the rotation speed is higher, about 8000rpm.

6. OPERATING INSTRUCTIONS

6.1 KEY ALIGNMENT

There are two ways to align the key: shoulder alignment and head alignment

- 1) Shoulder alignment as shown below

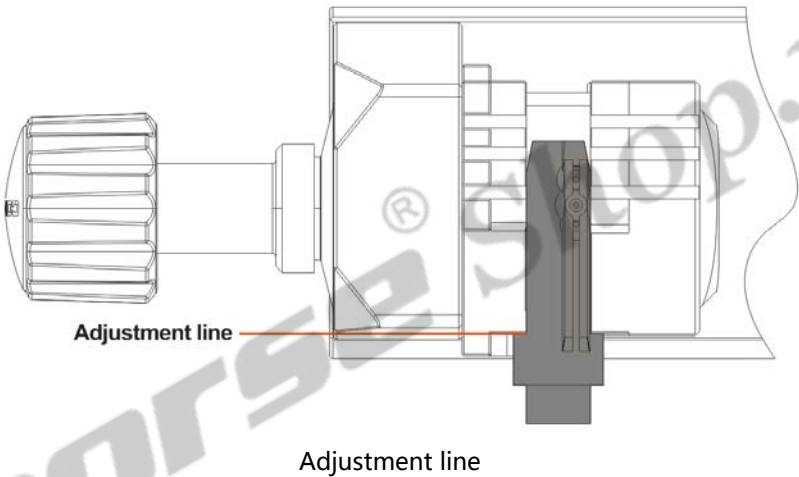

- 2) The position of head alignment as shown below, and 1, 2, 3 are the block blades for different key types.

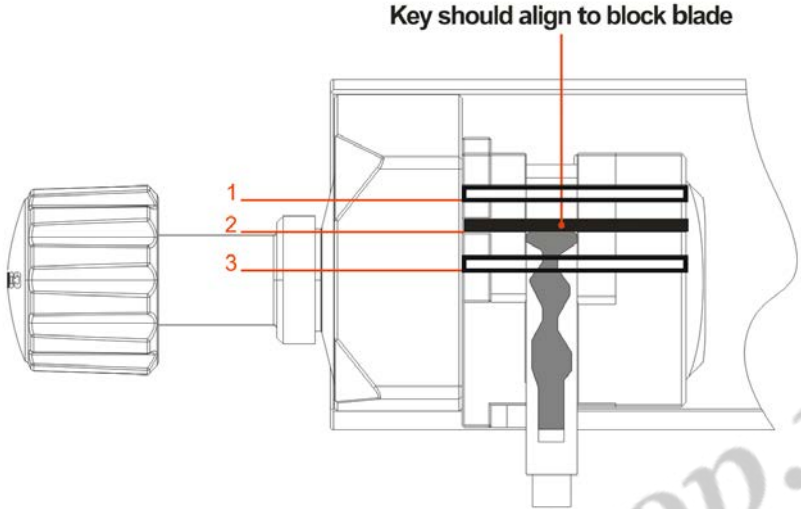

Key should align to block blade

xhorse® Shop.us

6.2 SELECTION RULES OF CLAMP SIDES

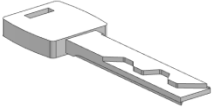
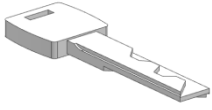
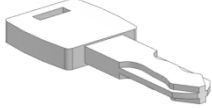
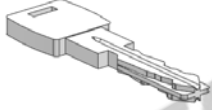
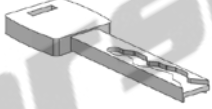
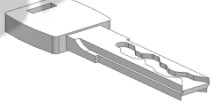
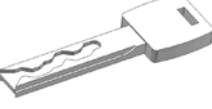
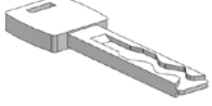
Key Type	Schema	Clamp side	Illustration
2 Track External		A/B	<p>1) The key type available for side A and D are the same, please make the selection according to the cutting depth.</p> <p>2) When cutting dimple key, please use the specific cutter.</p>
		A/C	
4 Track External		A/D	
		A/D	
Channel Track		A/D	
		A/B	
		A/C	
4 Track Internal		A/D	

Dimple		A/D	
---------------	---	-----	--

7. MAINTENANCE

- Before cutting, please use a brush to clean up the operating area. Since inclusions may cause corrosion or damages, and would eventually impact the accuracy of key cutting.
- Do not use any oily product or detergent to clean the components, because it may also lead to some damages or corrosion.
- Neither direct water rinse nor wet cloth wipe can be used on machine. Otherwise, electric leakage or metal rustiness will probably happen.
- Under no circumstance can cleaning equipment be used for operating area, such as air gun, blower etc. It is to avoid inclusions blowing into the machine and raise the unsafety of daily use.

8. WARRANTY AND AFTER SALES SERVICE

CONDOR XC-002 contains one-year warranty and the start date of period is subject to invoice; if with no invoice or has lost, then the date recorded by manufacturer shall prevail.

★ Following circumstances are not included in free maintenance:

- The malfunction caused by the operation not followed with user manual.
- The malfunction and damage caused by unauthorized repairs and alteration.
- The malfunction caused by fall, crash or improper voltage.
- Damage due to force majeure.
- Long time used in harsh places or vehicles, or the failure and damage caused by ship carrying.
- The malfunction arisen from everyday use, such as dirt or normal losses of shell and protective shield is excluded either.

To achieve more information about product' s after sales service and technical support, please contact dealer or scan the QR code below, and follow Xhorse official account (WeChat ID: SZ-Xhorse).



Xhorse

All rights reserved. Without permission, all copies or transmissions of any parts of this publication by any individuals or organizations in any ways are forbidden. Due to the continuous improvement, the content in this manual is subject to change without prior notice.

Xhorse® Shop.us

9. APPENDIX

 Xhorse® Shop.us